

MixedMode



Mixed Circuit-Device Simulation



SILVACO



Introduction

- The MixedMode module of ATLAS enables circuit simulation using physically-based models
- MixedMode Features:
 - Ability to link any ATLAS device into a SPICE circuit
 - Multiple ATLAS devices with independent models and material parameters
 - DC, transient and small signal AC analysis



Two Approaches to Get Circuit Performance from ATLAS Devices

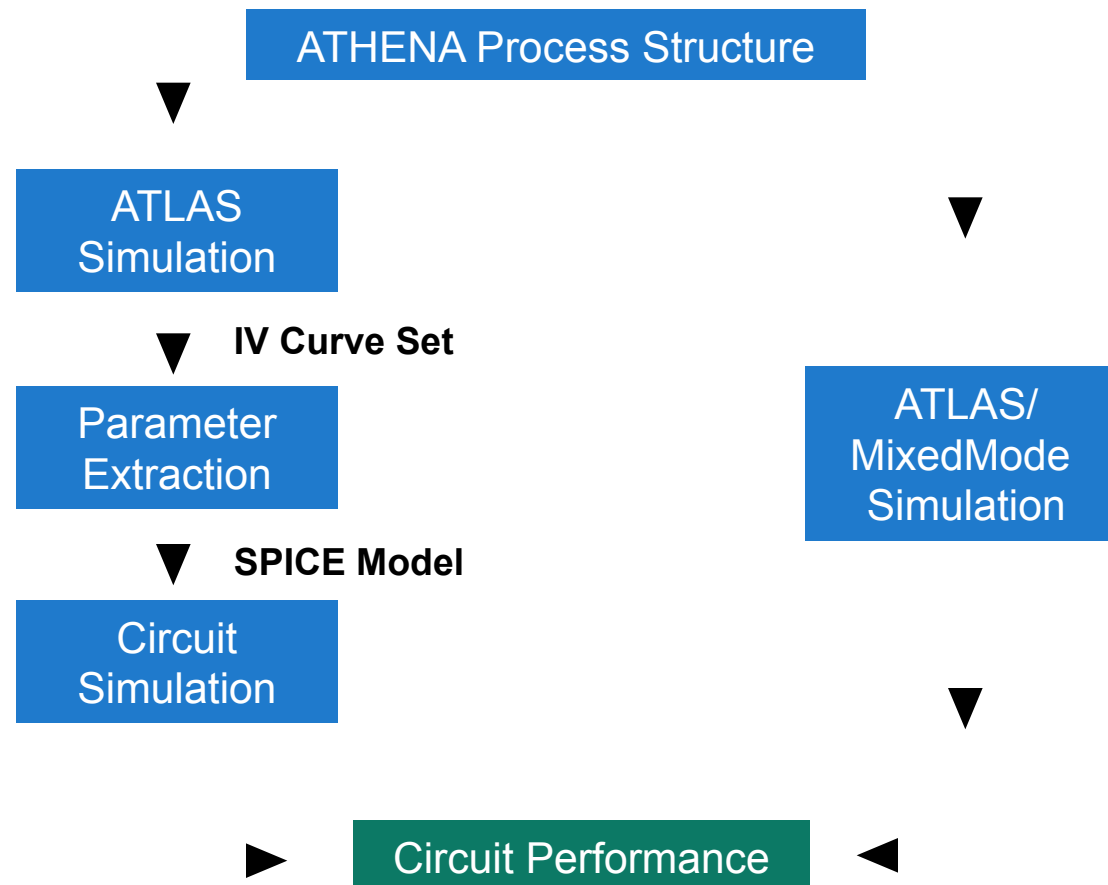



MixedMode Usage Guide

- Input decks have two sections: Circuit definitions and Physical Parameters
- Standard SPICE-like syntax for circuit definition and control bounded by .BEGIN and .END statements
- ATLAS devices are defined by Axxx. Electrode names linked to circuit nodes
`AGTO 0=CATHODE 7=ANODE 8=GATE WIDTH=3.E6 INFILE=GTO.STR`
- SmartSpice Analog Circuit Simulator model library used to provide accurate and comprehensive description of circuit elements including:
 - BJTs
 - MBTs
 - TFTs
 - MESFETs
 - SOIs
 - JFETs
 - Diodes



MixedMode Usage Guide (cont.)

- Regular ATLAS commands used to define material parameters and numerical tolerance (e.g. CONTACT, MATERIAL, METHOD, MODELS, TRAPS)
- Select different models or material parameters for different devices. MODELS DEVICE=Axxx
- Results saved via .LOG and .SAVE statements in circuit portion of input deck
- .NODESET parameter used to set initial voltages
- Voltages on ATLAS device automatically scaled so lowest is zero. Use .OPTIONS NOSHIFT to disable this
- Damping of voltage changes in circuit nodes during calculations can aid convergence greatly in DC mode. Use NUMERIC VCHANGE=<r>



MixedMode Example

- Gate-Turn-off Thyristor (GTO) are frequently used in an inductive load switching circuit. They experience the condition of both high current density and high voltage
- The switching performance of a GTO depends strongly on the external circuit
- The following example demonstrates the isothermal transient simulation of the GTO in a circuit



GTO Structure Definition

```
go atlas
# GTO Geometry and doping distribution
# SILVACO International
#
mesh outf=gto.str

x.mesh loc=0.0 spac=12.0
x.mesh loc=100 spac=2.0
x.mesh loc=125 spac=5.0
x.mesh loc=150 spac=2.0
x.mesh loc=280 spac=13.0

y.mesh loc=0.0 spac=5.0
y.mesh loc=13.0 spac=0.4
y.mesh loc=17.0 spac=2.0
y.mesh loc=70.0 spac=10.0
y.mesh loc=200.0 spac=50.0
y.mesh loc=410.0 spac=10.0

region num=1 silicon x.min=0 x.max=100 y.min=0 y.max=13
region num=2 silicon x.min=0 x.max=280 y.min=13 y.max=410
region num=3 insulator x.min=100 x.max=280 y.min=0 y.max=13
```



GTO Structure Definition (cont.)

```
# 1- Cathode; 2- Anode; 3-Gate
elec num=1 top left length=100 name=cathode
elec num=2 bottom name=anode
elec num=3 x.min=150 x.max=280 y.min=0. y.max=13. name=gate
#
# Impurity profile
#
doping reg=2 uniform conc=1.e13 n.type
doping reg=2 gauss conc=1.e17 p.type junc=47
doping reg=1 gauss conc=1.e19 n.type junc=16 x.l=0 x.r=100 rat=0.8
doping reg=2 gauss conc=1.e20 p.type peak=410 junc=393 x.l=0 x.r=170 rat=0.1
doping reg=2 gauss conc=1.e17 n.type peak=410 char=10 x.l=170 x.r=280
#
quit
```



GTO Steady State Solution

```
go atlas
.begin
#
# Turn-off of GTO with protection circuitry
# SILVACO International
#
# Part 1: Steady state solution
#
i1 0 1 400.
d1 1 2 dd
v1 2 0 900
r1 1 3 1
l1 1 4 4uH
#
d2 5 3 dd
l2 4 5 4uH
r2 4 6 22
#
d3 5 6 dd
l3 5 7 0.2uH
c1 6 0 0.22uF
#
agto 0=cathode 7=anode 8=gate width=3.035e6 infile=gto.str
#
d4 12 8 dd
l4 8 9 0.5uH
r4 9 11 1mg
```



GTO Steady State Solution (cont)

```
#
v2 12 0 -25
v3 11 0 -12
#
r3 9 10 5.4
#
v4 10 0 12
#
.nodeset v(1)=0 v(2)=900 v(3)=0 v(4)=0 v(5)=0 v(6)=0 \
        v(7)=0. v(8)=0 v(9)=0 v(10)=12 v(11)=-12 v(12)=-25
#
.numeric toldc=1.e-6 vchange=0.025 imaxdc=100
.save outfile=gto_save
.model dd d is=1e-7
.options m2ln relpot print
.end
#
models device=agto reg=1 analytic fldmob srh auger bgn
models device=agto reg=2 analytic fldmob srh auger bgn
material device=agto reg=1 taun0=2.4e-6 taup0=0.6e-6
material device=agto reg=2 taun0=2.4e-6 taup0=0.6e-6
material device=agto reg=3 PERM=1
impact device=agto selb reg=1
impact device=agto selb reg=2
#
quit
```



GTO Transient Solution

```
go atlas
.begin
#
# Turn-off of GTO with protection circuitry (tr)
# SILVACO International
#
# Part 2: Transient solution
#
i1 0 1 400.
d1 1 2 dd
v1 2 0 900
r1 1 3 1
l1 1 4 4uH
#
d2 5 3 dd
l2 4 5 4uH
r2 4 6 22
#
d3 5 6 dd
l3 5 7 0.2uH
c1 6 0 0.22uF
#
agto 0=cathode 7=anode 8=gate width=3.035e6 infile=gto.str
#
d4 12 8 dd
l4 8 9 0.5uH
r4 9 11 1mg PULSE 1mg 1.e-6 0 100ns 100ns 10 1000
#
v2 12 0 -25
v3 11 0 -12
```



GTO Transient Solution (cont)

```
#
r3 9 10 5.4
#
v4 10 0 12
#
.numeric lte=1 vchange=1000 dtmin=0.1ps
#
.tran 25ns 400us
.load infile=gto_save
.log outfile=gto
.model dd d is=1e-7
.options print
.end
#
models device=agto reg=1 analytic fldmob srh auger bgn
models device=agto reg=2 analytic fldmob srh auger bgn
material device=agto reg=1 taun0=2.4e-6 taup0=0.6e-6
material device=agto reg=2 taun0=2.4e-6 taup0=0.6e-6
material device=agto reg=3 PERM=1
impact device=agto selb reg=1
impact device=agto selb reg=2
#
quit
```



Gate Turn-Off Thyristor Power Device Circuit

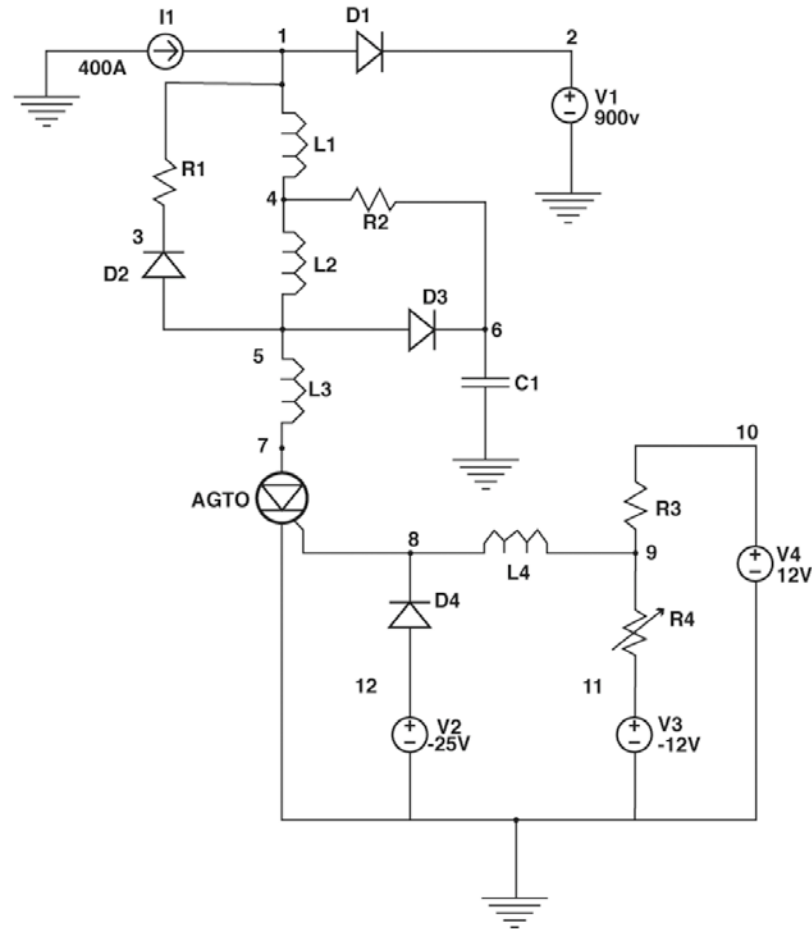



GTO Transient Simulation Results

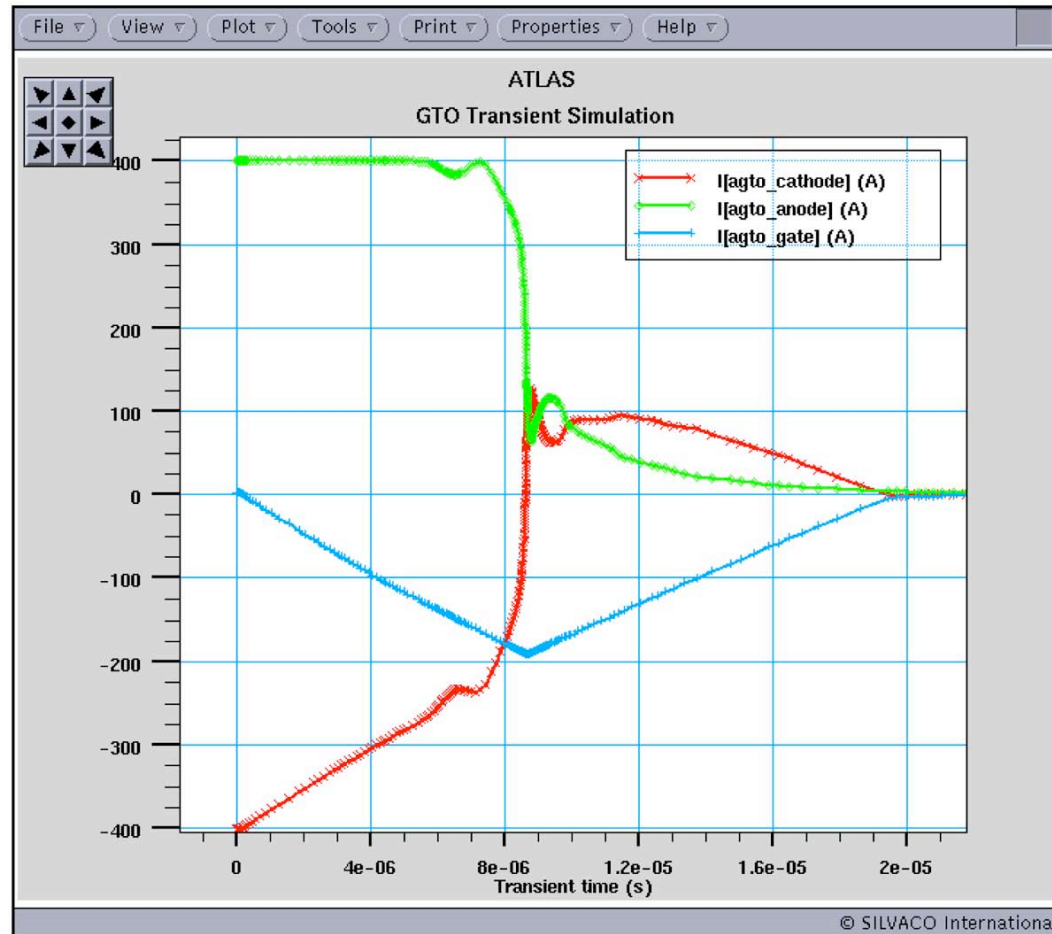



Conclusions

- MixedMode enables the simulation of ATLAS devices within a circuit environment
- Wide range of SPICE models available
- MixedMode circuits can include up to 100 nodes, 300 elements and 10 ATLAS devices